

PRODUCT BRIEF

Fiber Array For Optical Transceivers

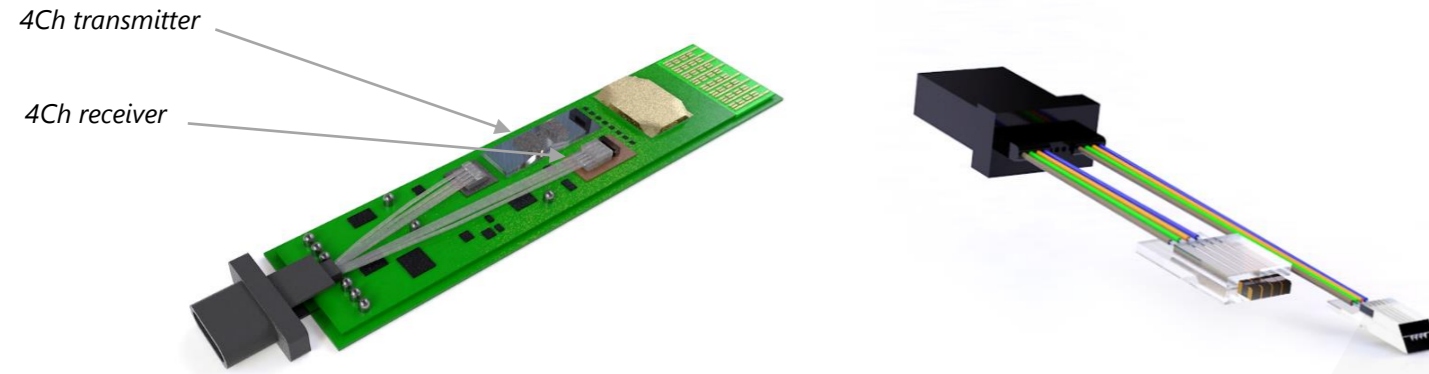

Yilut's Fiber Array Assembly for 400G DR4 Optical Transceivers



MT to 2x FA

Yilut is dedicated to developing and manufacturing customer specified fiber array assembly to meet dramatic increasing demand for optical transceivers in datacenters.

Yilut's solution for 400G QSFP-DD DR4 enable and utilize the potential of Silicon Photonics based technology in delivering low-cost, high-volume fabrication, and highly integrated solution for optical transceivers.

As the technology is widely adopted for telecommunication, Data Communications, Medical Technology, Security and Sensing. The future needs of optical transceivers would be enormous.

Feature

- Application for Datacenter and enterprise

Device Schematic Drawing (unit: mm):

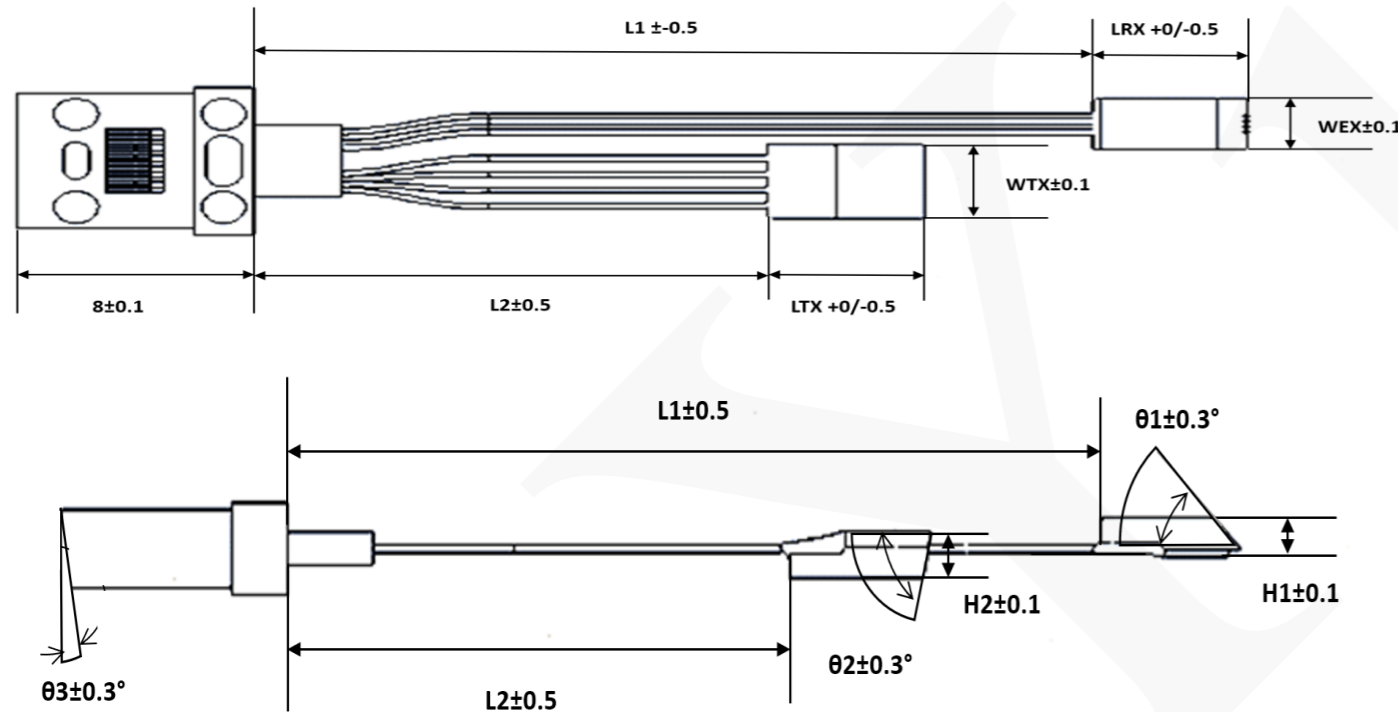

Customer Specified parameters available

Parameter	Unit	Value
Channel Pitch	um	250/500/750/1100/1500/per client specification
Insertion Loss of TX	dB	0.3/0.5
Insertion Loss of RX	dB	0.3/0.5
Return loss of TX	dB	35
Return loss of RX	dB	20
Fiber tube	/	0.25/0.35Hytel+Nylon
Fiber Length	mm	Min18
Operating Temperature	°C	-10~85
Storage Temperature	°C	-40~85

Parameter	Unit	Value
L1	mm	Min20
L2	mm	Min18
H1	mm	Min0.85
H2	mm	Min1.0
WRX	mm	Min2.0
WTX	mm	Min3.0
θ1	°	42.5/45/per client specification
θ2	°	8/0/per client specification



Contact us

Wuhan Yilut Technology Co., Ltd
 www.yilut.com / sales@yilut.com
 phone: +86 (0)27 8780 8675

If you are interested to know more, feel free to drop us a line.